

# AT75C310

## SMART INTERNET APPLIANCE PROCESSOR

A total single-chip solution including IC, operating system and application software for Internet audio appliances

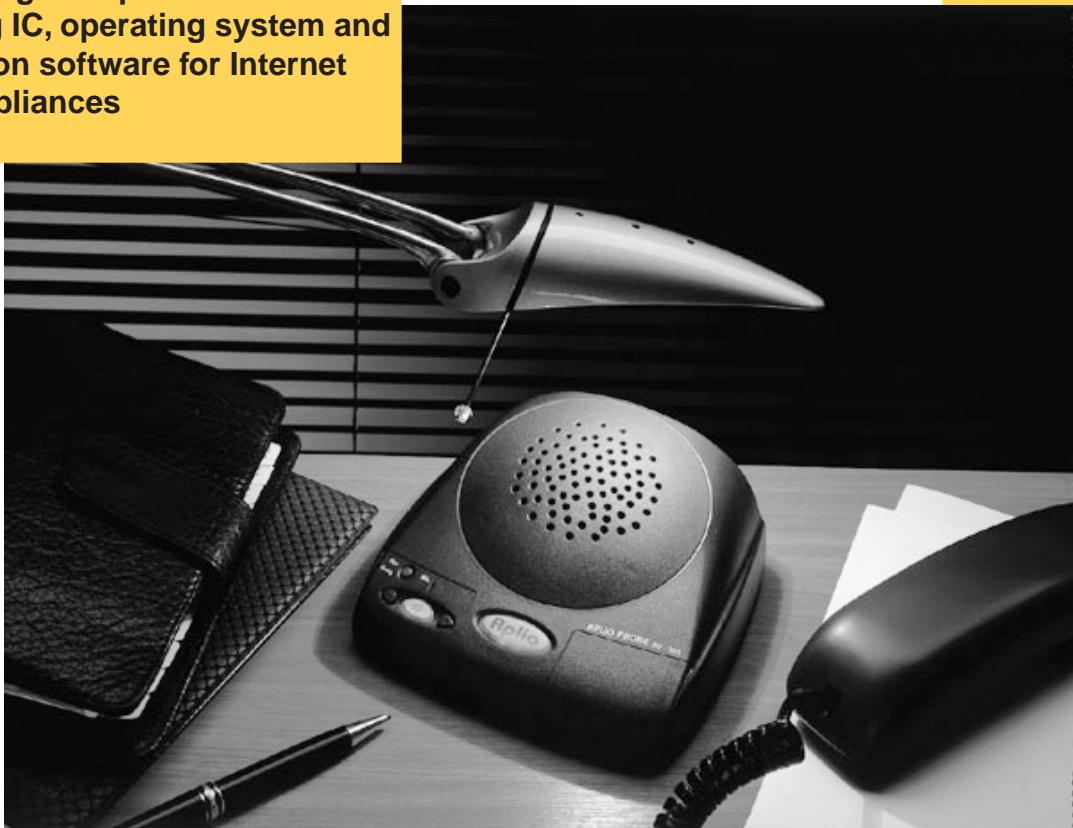

AplicorPhone by Aplia

- Single-chip solution for Voice over Internet Protocol (VoIP)
- Simultaneously handles voice processing, telephony and VoIP protocol stack tasks
- Applications include Internet phones, Web radios, MP-3 digital music players
- Single-chip solution reduces system cost
- Programmable standard product for fast time-to-market
- Proven technology
- Based on 32-bit ARM7TDMI™ processor core and advanced peripherals
- Includes two 16-bit fixed-point OakDSPCores™
- 88k bytes of integrated fast RAM for each DSP core
- Peripheral Data Controller for fast DMA
- Flexible External Bus Interface includes DRAM controller
- 48 general-purpose I/O pins
- 160-lead PQFP package

## Telephone Products Marketing

## USA

Tel : (+1)(719) 540-1834

Fax : (+1)(719) 540-1759

## France

Tel : (+33)(0)4 42 53 61 29

Fax : (+33)(0)4 42 53 60 01

## United Kingdom

Tel : (+44)(0) 1355 357000

Fax : (+44)(0) 1355 242743

## Corporate Headquarters

2325 Orchard Parkway

San Jose, CA 95131

## USA

Tel : (+1)(408) 436 4228 / 487 2610

Fax : (+1)(408) 436 4300

## Europe

Atmel U.K. Ltd

Coliseum Business Centre

Riverside Way, Camberley

Surrey GU15 3YL, England

Tel : (+44)(0)(1276) 68 66 77

Fax : (+44)(0)(1276) 68 66 97

## Asia

Atmel Asia Ltd

Room 1219

Chinachem Golden Plaza

77 Mody Road

Tsimshatsui East, Kowloon

Hong Kong

Tel : (+852) 272 19 778

Fax : (+852) 272 21 369

## Japan

Atmel Japan KK

Tonetsu Shinkawa Bldg, 9F

1-24-8 Shinkawa

Chuo-Ku, Tokyo 104-0033

Japan

Tel : (+81) 3 3523 3551

Fax : (+81) 3 3523 7581

## E-mail

literature@atmel.com

## Web Site

http://www.atmel.com



© Atmel Corporation 2000

Terms and product names may be trademarks of others. All figures in this brochure are for illustrative purposes only. See Atmel data books for definitive figures and for applicable limitations and warranties.

1357A-01/00/12M

The Atmel AT75C310 Smart Internet Appliance Processor (SIAP) is built around an ARM7TDMI microcontroller core, with two autonomous DSP co-processors, all three delivering unmatched performance for low power consumption. In a typical standalone VoIP phone, one DSP handles the voice processing functions (voice compression, acoustic echo cancellation, etc.), while the other deals with the telephony functions (dialing, line echo cancellation, callerID detection, high-speed modem, etc.). The power of the ARM7TDMI allows it to run the VoIP protocol stack as well as all the system control tasks.

## ARM7TDMI Core

The ARM7TDMI is a 3-stage pipeline, 32-bit RISC processor. It has two instruction sets, the 32-bit ARM set for maximum performance, and the 16-bit Thumb set for maximum code density.

The CPU has seven operating modes, each with dedicated banked registers for fast exception handling.

## DSP Subsystem

The AT75C310 has two identical DSP subsystems, each comprising:

- an OakDSPCore running at 40 MIPS
- 2Kx16 of X-RAM and 2Kx16 of Y-RAM
- 16Kx16 of general purpose data RAM
- 24Kx16 of loadable program RAM
- one 256x16 dual-port RAM mailbox for MCU-DSP communication
- one codec interface

Each DSP subsystem is fully autonomous. The local X- and Y-RAM allows it to reach its maximum processing rate, and a local large data RAM enables complex DSP algorithms to be implemented. The large size of the program RAM permits the use of functions as complex as a V34 modem or a low bit-rate vocoder.

The codec interface allows the connection of most industrial voice, multimedia or data codecs.

## Applications Software

The AT75C310 is supported by a comprehensive range of software modules at three levels:

## OS Level

The AT75C310 is supplied with a customized port of the Linux kernel.

## DSP Level

A wide range of DSP functions is available for the OakDSPCore. Amongst others, Atmel supplies modules for a V34 modem, G723.1

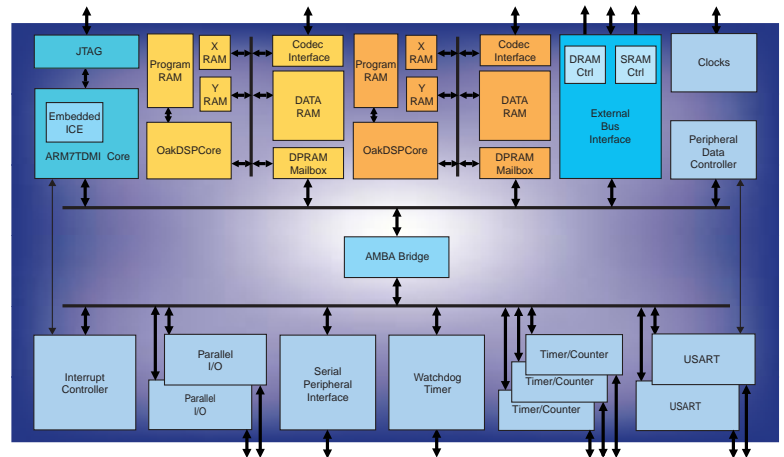

AT75C310 Block Diagram

and G729A voice codecs, silence compression and echo cancellation.

## Application Level

Atmel's partner in the development of the AT75C310 is Aplio, a worldwide leader in embedded communications technologies for Internet appliance applications. Aplio provides a rich software toolkit with support for popular communication protocols (H323, POP/SMTP, etc.), connection processes, full-feature telephony and audio software suites, etc.

## Development Tools

The industry-standard ARM7TDMI and the OakDSPCore are supported by a comprehensive range of state-of-the-art development tools, including assemblers, C-compilers, source level debuggers and hardware emulators.

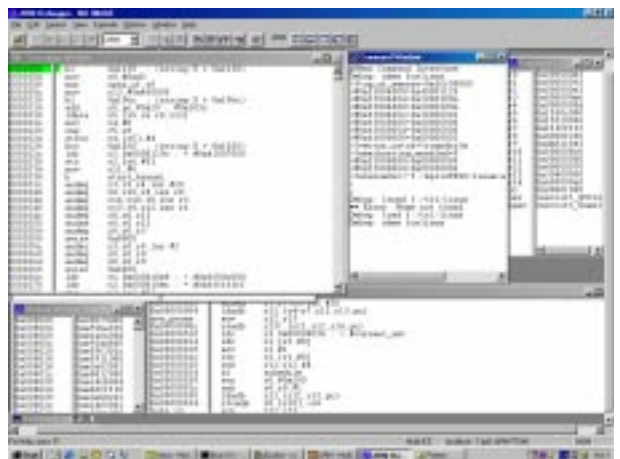

AT75C310 Development Tools